

**ENGINES**

## **MARINE DIESEL ENGINE SV-230**

**BASED ON VM - 6 CYLINDERS 230 HP.**

**TURBO**  
Intercooler

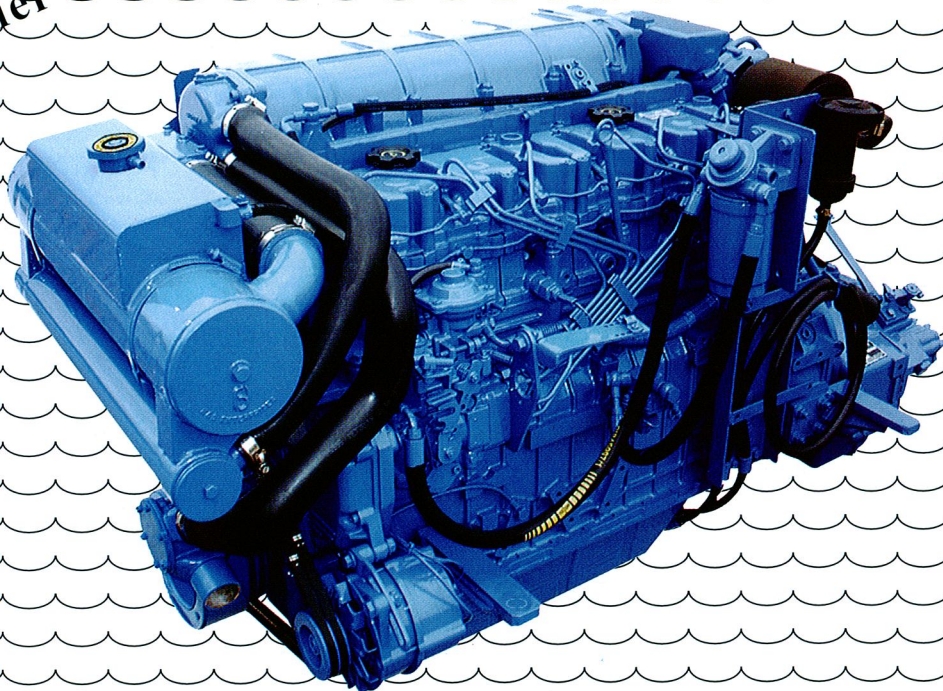

### **General characteristics**

This modern diesel marine engine is outstandingly rugged, reliable, with a compact size, low weight and a great power delivery, that make the engine highly versatile, for use in recreational vessels.

### **Combustion system**

The direct injection system with rotative injector pump, and mechanical regulator provide low consumption and high performance across the range of revolutions, as well as a low level of noise and vibrations.

### **Cooling system**

The fresh-water cooling system based on a thermostatically controlled valve and heat exchanger keeps engine temperature constant at any rpm.

### **Electrical system**

The electrical system is 12 V, with a 70 Amp. alternator and built-in electronic regulator. A comprehensive control panel with sound alarms protects the engine efficiently from any possible incident.

The electrical system is mounted on the engine, with an oil pressure gauge and a cooling liquid temperature thermometer.

### **Gearbox**

The high performance hydraulic gearbox makes it possible to mount both right and left spin propellers. The motor can be supplied with other gearbox types to suit customer requirements.

# SV-230

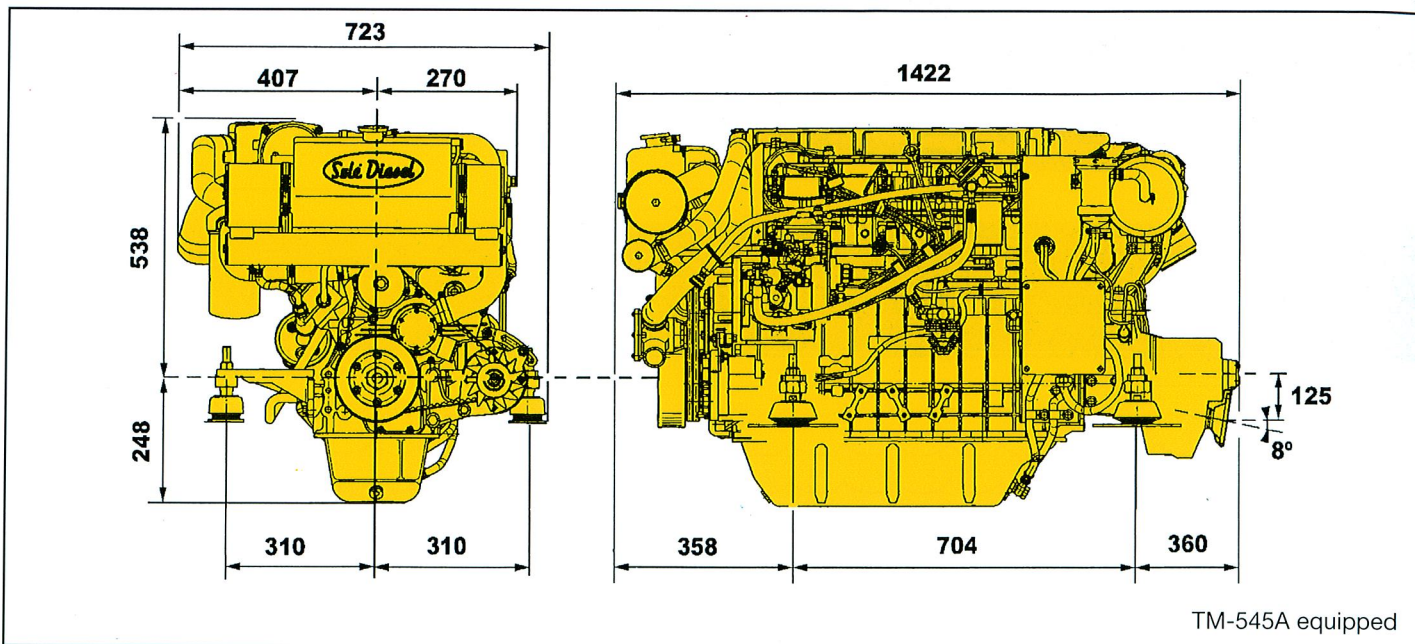

TM-545A equipped

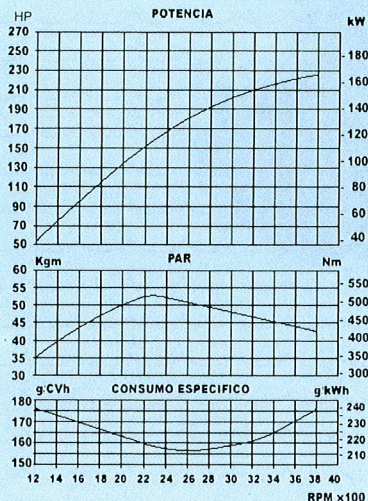

## SPECIFICATIONS

Type .....	Diesel , 4 stroke, turbo-intercooler
Nº of cylinders .....	6 in line
Bore x stroke mm (in) .....	94 x 100 (3.70 x 3.93)
Total displacement cc. (cu. in.) .....	4164 (254)
Compression ratio .....	17:1
Max. Output interm ISO 3046/1 .....	230HP (169 kW)
Max speed (r.p.m.) .....	3800
Injection system .....	Direct
Cooling system .....	Coolant heat exchanger with water cooled exhaust manifold.
Electrical system .....	12V. Starter motor 3 kW. 70 Amp. alternator
Gearbox (Hydraulic) .....	TECHNODRIVE TM 545A
Reduction ratio .....	1'5:1, 2'09:1.
Weight with hydraulic gearbox Kg (lbs.) ..	465 (1026.4)
Installation angle .....	15° continuous- Intermittent 20°

### Standard equipment:

Electrical starter and alternator, electric stop, control panel with tachometer, hour counter, starter switch, water temperature gauge, audible alarm for oil and water, oil pressure gauge and voltmeter. Oil filter, cooled exhaust manifold, flexible mountings, 4 mts wirings and connection kit for control cables.

### Optional equipment:

Water filter, fuel filter with water separator, remote engine control, propeller shaft, stern tube and propellers.

*Specifications are subject to change without prior notice.*

Importer:

Dealer: