

MARINE
DIESEL
ENGINES

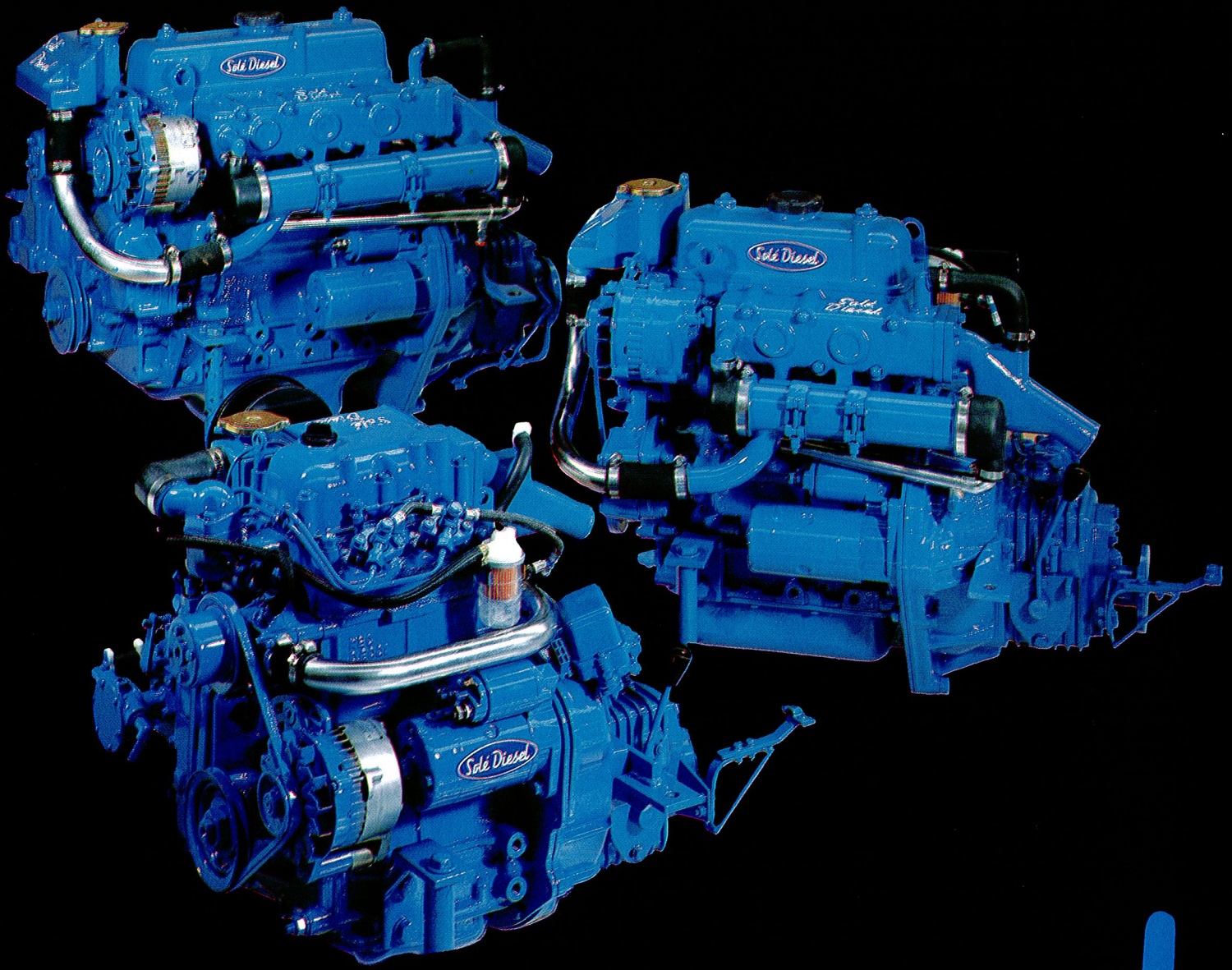

Solé Diesel

THIS EXCITING NEW RANGE OF SOLÉ MARINE DIESELS

provide quiet, lightweight, compactness which will delight those seeking performance and reliability. Thanks to their efficient design and construction, clean exhaust emission and smooth running features, very little servicing is needed and maintenance costs are therefore minimal. These robust multi-cylinder, low profile engines are designed to fit yachts, motor boats and fishing launches from 16ft (5 mtrs) to 50ft (15 mtrs) approx.

All Solé Mini diesels are fitted with a combined heat exchanger, header tank and water cooled exhaust manifold AS STANDARD — isolating the raw seawater in components which are designed to withstand its corrosive effect, thus the cast iron cylinder block and head are protected from corrosion and silt settlement in the thermostatically controlled fresh water circuit, ensuring the engine operates at its designed temperature.

ENGINE SPECIFICATION

Vertical watercooled four stroke overhead valve multi-cylinder compression ignition engines with special swirl type combustion chamber system. Cast iron cylinder head & crankcase with integral flywheel bellhousing and detachable sump. Thermostatically controlled cooling with heat exchanger system and water cooled exhaust manifold circulated by a self priming flexible vane pump. Fuel injection is by Bosch M type pump. Rotary oil pump pressure feed lubrication system is through a disposable can filter. An oil

TECHNICAL DATA

ENGINE TYPE		MINI 10	MINI 14	MINI 23	MINI 34
NUMBER OF CYLINDERS		2	2	3	4
BORE	mm (ins.)	65 (2.56")	70 (2.76")	73 (2.87")	73 (2.87")
STROKE	mm (ins.)	68 (2.68")	78 (3.07")	78 (3.07")	78 (3.07")
CYCLE		4 STROKE			
CUBIC CAPACITY	cc (cu. ins.)	451 (27.52")	600 (36.61")	979 (59.74")	1305 (79.63")
COMPRESSION RATIO		23.1	23.1	23.1	23.1
OUTPUT (DIN 6270B) 3000 RPM	HP (kW)	9 (6.62)	13 (9.5)	20 (14.92)	31 (22.81)
FUEL CONSUMPTION @ 2200 RPM	Pints hr	2.5	4	6.75	7.5
	Litres hr	1.49	2.3	3.8	4.2
LUBRICATING OIL CAPACITY	ENGINE litres	1.81	2.51	3.51	4.51
	GEARBOX litres	0.41	0.41	0.41	0.41
COOLING SYSTEM		FRESH WATER WITH HEAT EXCHANGER			
INJECTION PUMP		BOSCH M			
GEARBOX CONSTANT MESH					
MECHANICAL TYPE RATIO		1.91:1	1.91:1	2:1	2:1
PROPELLER SHAFT ROTATION		CLOCKWISE VIEWED FROM STERN			
ELECTRICAL SYSTEM 12 VOLT	STARTER kW	0.9	1.1	1.6	2
	ALTERNATOR amps	35	35	35	50
INSTALLATION ANGLE	Max	20°	20°	20°	20°
ENGINE/GEARBOX	Dry Weight kg	90	105	155	177
	lbs	198	231	341	390

The above data is subject to change without notice

evacuation sump pump is fitted for ease of oil changes. Starting is by 12v. electric motor with alternator for battery charging. Heater plugs for cold starting are fitted together with a remote stop control. The engine mounted air cleaner has a replaceable element. The fuel filter is a disposable type. A mechanical fuel lift pump is fitted. The gearbox is a 2:1 reduction, constant mesh mechanical type with forward, neutral, and reverse gears, with connections to accept single lever remote control cables.

INSTALLATION EQUIPMENT

Fitting a marine engine will vary according to hull configurations. The illustration below indicates the typical requirements for a new installation. Not all of the items illustrated may be required where a vessel is to be re-engined as it may be possible to utilise part of the existing equipment if compatible. It is essential to adopt the correct practices if a good installation is to be achieved. Advice on any particular aspect of installation can be given by our technical department.

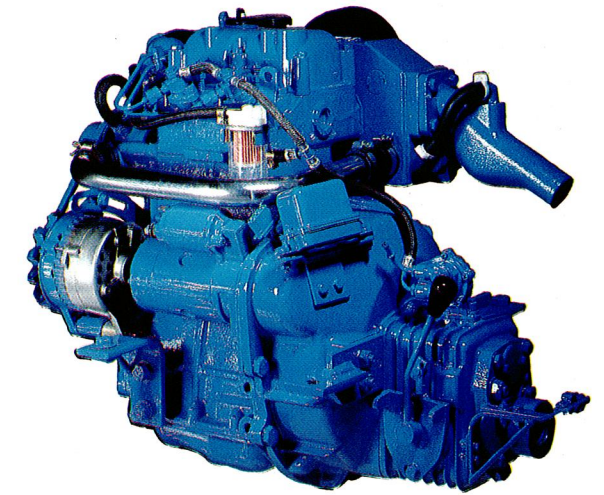

MINI-10

MINI-14

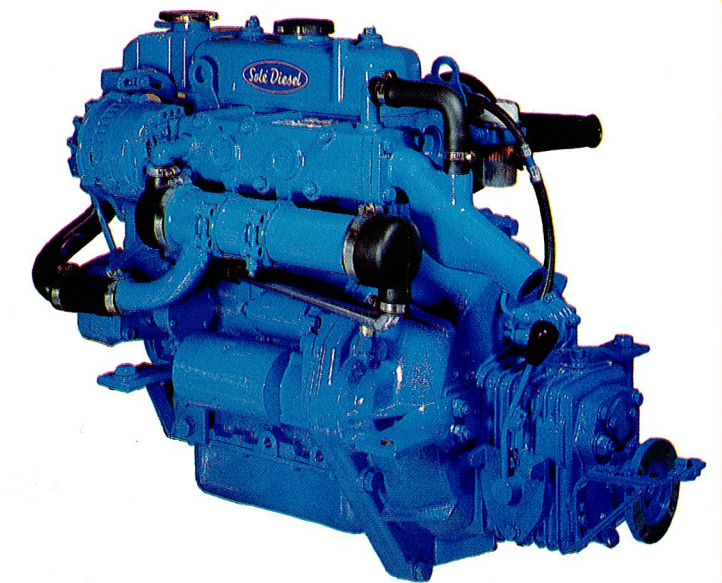

MINI-23

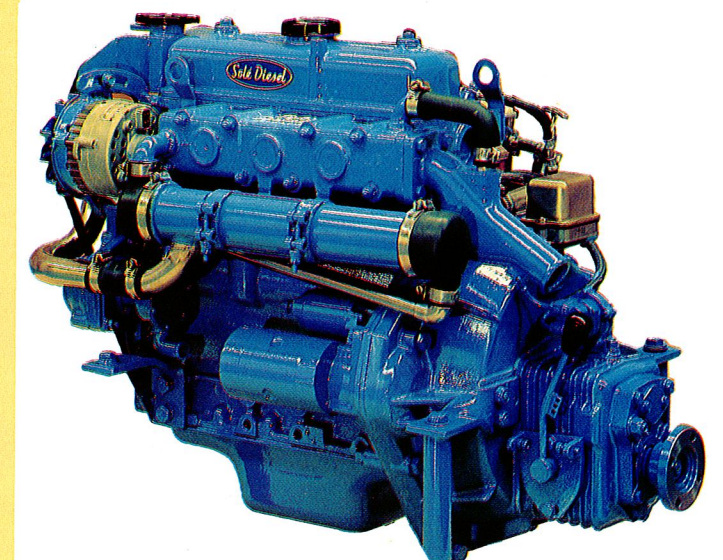

MINI-34

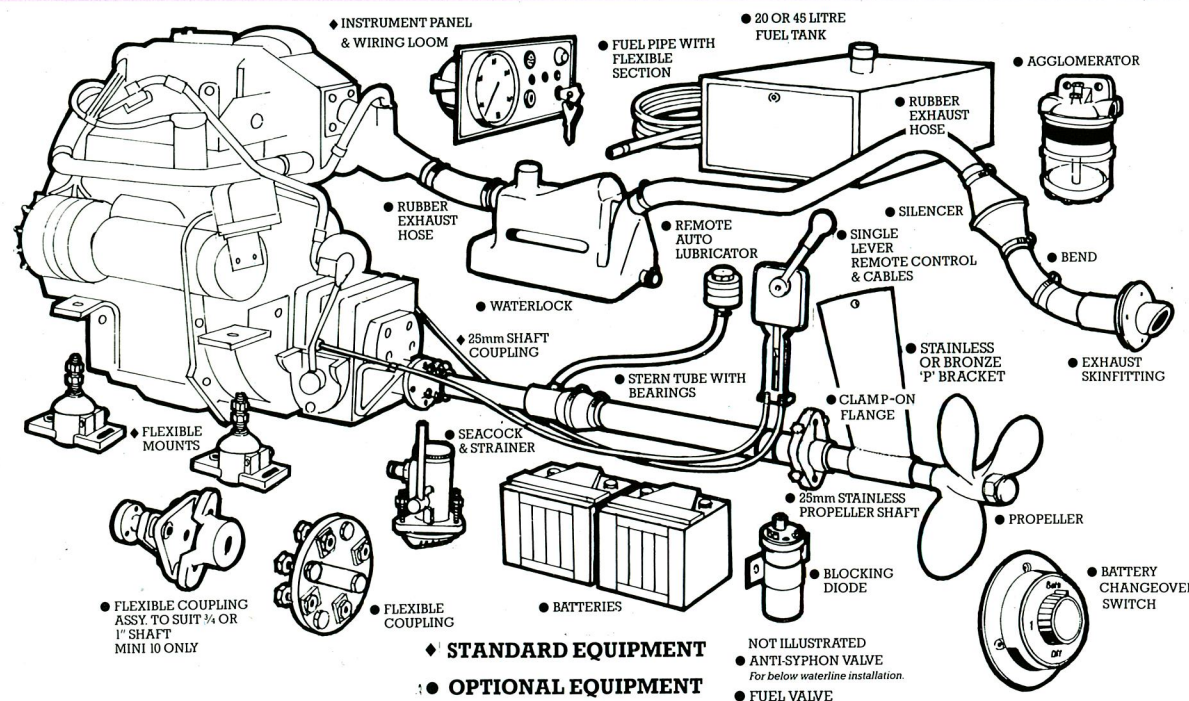

◆ STANDARD EQUIPMENT

● OPTIONAL EQUIPMENT

NOT ILLUSTRATED
● ANTI-SYPHON VALVE
For below waterline installation.
● FUEL VALVE

◆ STANDARD EQUIPMENT SUPPLIED WITH ENGINE

- 1 set (4) Flexible Mounts.
- 1 25mm. shaft coupling.
- 1 Sump pump (fitted)
- 1 set Remote control cable connections (fitted)
- 1 Switch panel fitted with:—
 - a. Tachometer
 - b. Key switch
 - c. Audible warning
 - d. Push button stop
 - e. Warning lamp — Charge
 - f. Warning lamp — Temperature
 - g. Warning lamp — Oil pressure
 - h. Wiring harness (2 mtr.)
- 1 Operators Manual
- 1 Tool Kit
- 1 Warranty Certificate

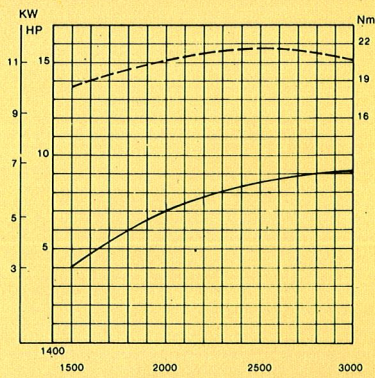

MINI-10

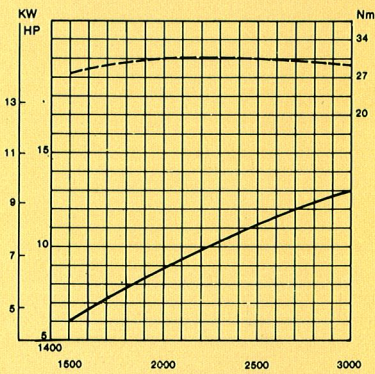
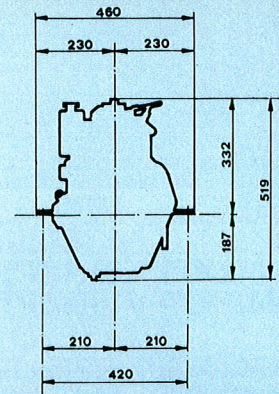
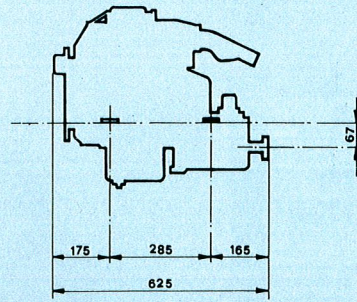

MINI-14

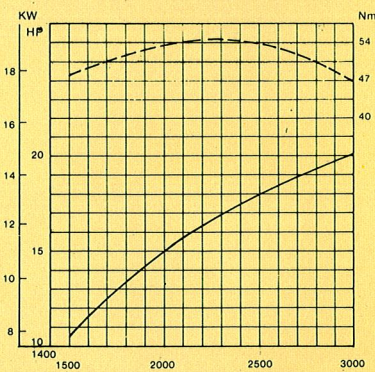
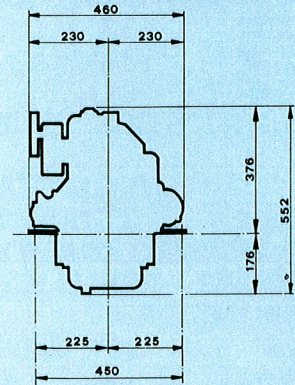
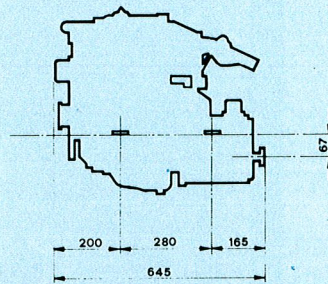

MINI-23

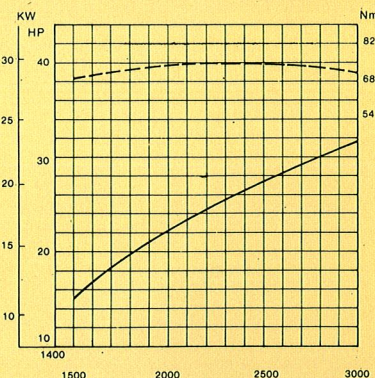
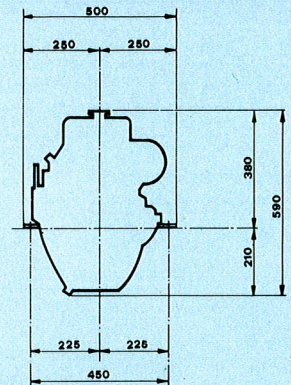
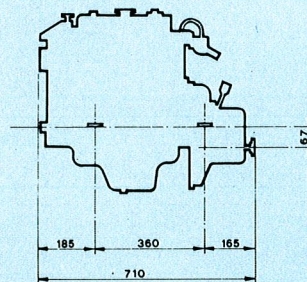

MINI-34

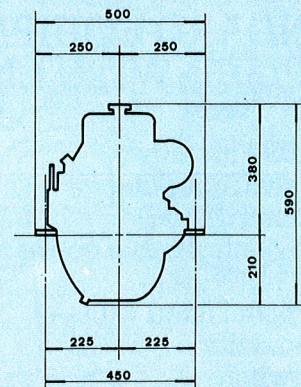
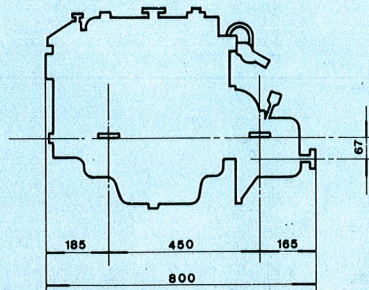

IMPRESO EN ESPAÑA - GRÁFICOS MARTORELL, S.L. - DEP. LEGAL B-32125-84



FAIRWAYS Marine Engineers

Bath Place Wharf, Downs Road, Maldon, Essex

Telephone: Maldon (0621) 52866/59424 Telex: 995548 LEDA G

Prices and specifications are subject to amendment without notice and all information is given subject to the Company's current conditions of tender and sale.